

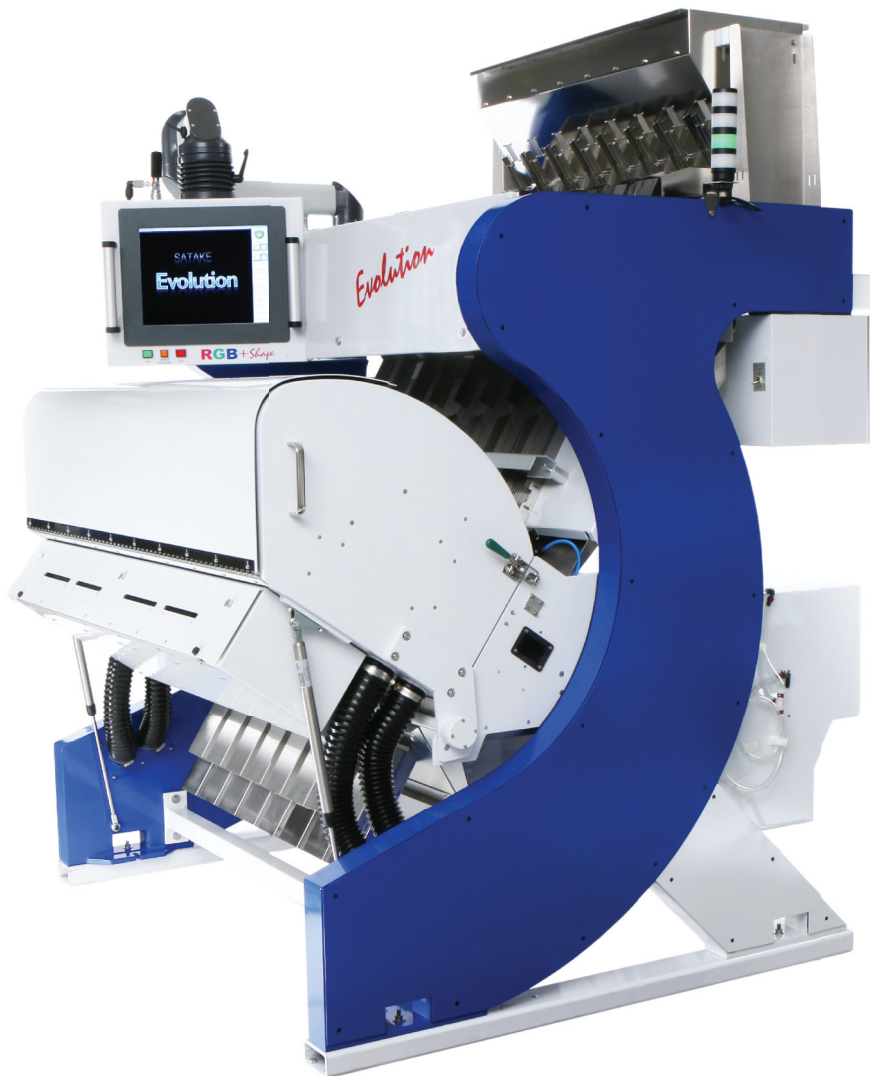

EVOLUTION® Series

The highest standard in **optical sorting technology** for the agriculture and bulk solids industry.



SATAKE



Typical Sorting Applications.



Coffee



Corn



Grains



Nuts



Plastics

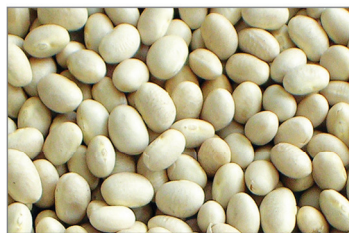

Pulses



Seeds



Spices

Experience Matters.

Optical sorting technology has come a long way since Satake introduced the first electric color sorter over 80 years ago. The combined experience of Satake sales, support, and engineering personnel far exceed hundreds of cumulative years in the industry. This unmatched level of professional service, experience and dedication is a benefit that comes standard on every EVOLUTION® manufactured.



Constantly Evolving Sorting Technology since Introducing the First Color Sorter in 1931.

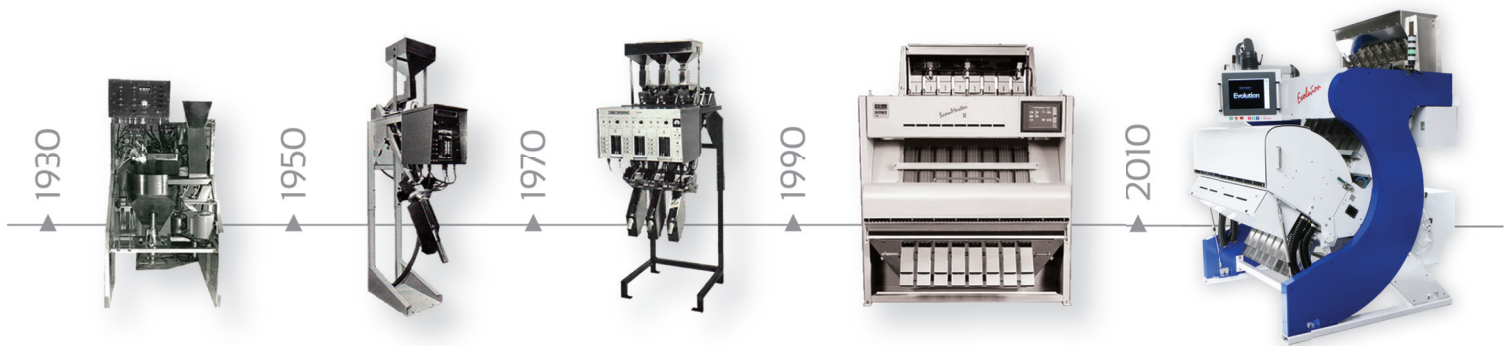

The highly successful EVOLUTION series of sorters now combines shape technology to offer the ultimate solution to many applications. Both the human eye and the EVOLUTION detect color through three wavelengths (red, green and blue), allowing the sorter to match the eye's ability to see true color. The smallest color deviations are identified and rejected. **This machine really is the r-Evolution of optical sorting.**

Satake. Trust the Experience.

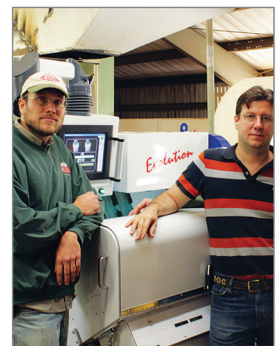
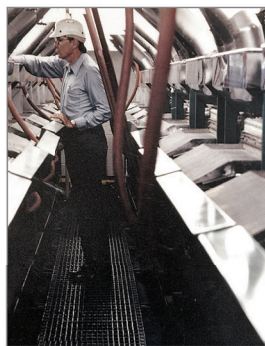
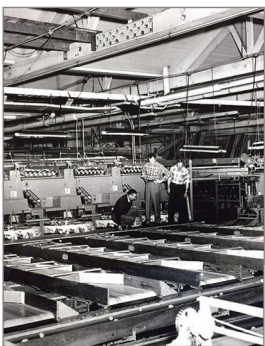

Features and Benefits.

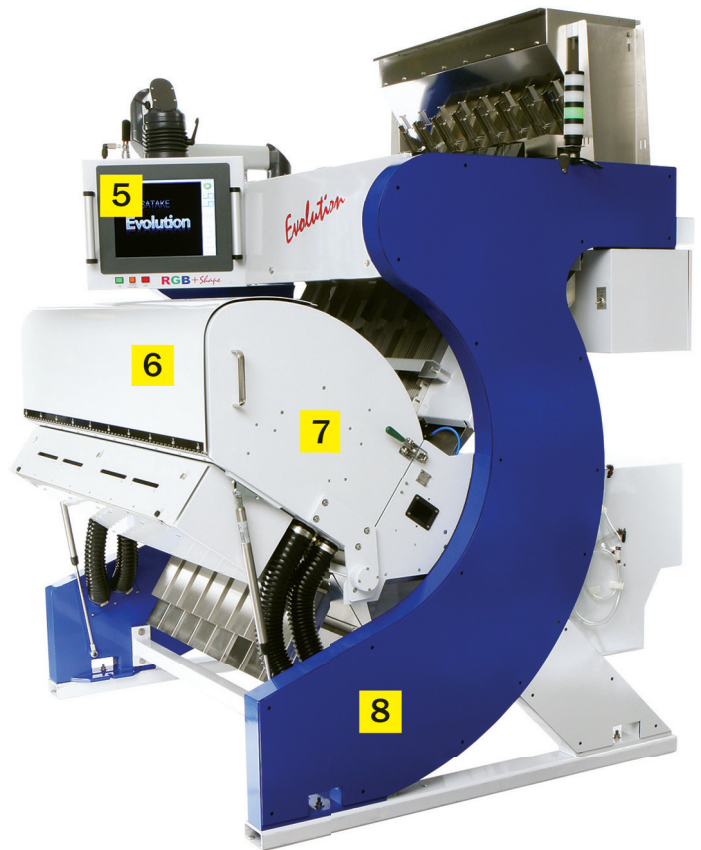

1 Product Supply System

A high capacity product feed system, using either 4 or 8 chutes, delivers a consistent product flow to the viewing area.

2 Multilingual Touch Screen Interface

Movable screen to observe the defect image data during product set up. Easy to use proprietary software is translated into multiple languages.

3 High Precision Air Ejectors

High ejector density design for concentrating the precision air blast to remove the defective product from the acceptable stream.

4 Secondary and Tertiary Resorting

Various options and configurations are available to ensure the best possible sort and achieve the most concentrated rejects in the industry.

5 Satake-EveryWhere

Internet access for remote administration and support system enables real time machine operation from any computer.

6 Full Color RGB Cameras

True color technology allows accurate mapping. Ideal for detecting multiple colored applications or minor shade differences.

7 Patented LED Illumination

Patented solid state, long life, high intensity LED illumination system that maximizes defect recognition.

8 Superior Quality Manufacturing

Manufactured in the United States using only the highest quality parts and components available to ensure years of trouble-free use.

Technical Specifications.

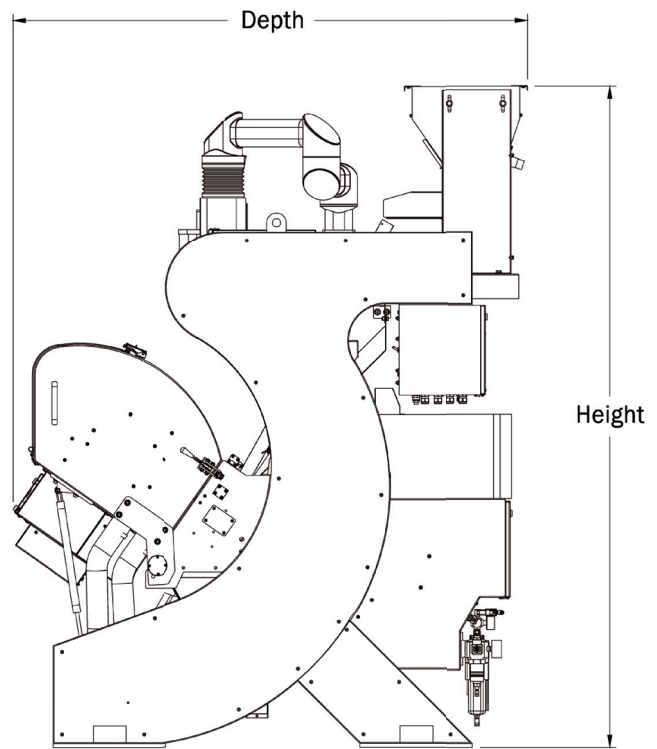
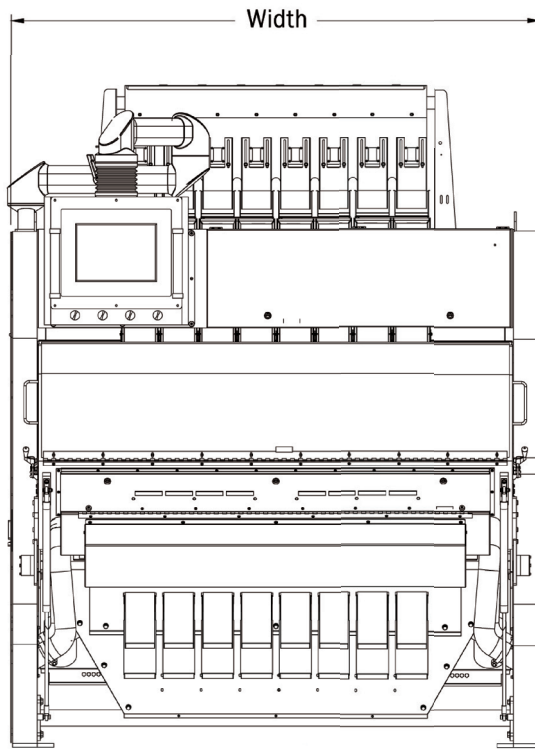

Dimensions

Machine	Width in. (mm.)	Depth in. (mm.)	Height in. (mm.)	Weight lbs. (kgs.)
EVOLUTION 4	52.2 (1326)	62.8 (1595)	80.9 (2055)	1299 (589)
EVOLUTION 8	64.5 (1638)	62.8 (1595)	80.9 (2055)	1542 (699)

Installations should allow a minimum of 39 inches around the machine for service access.

Power and Air Requirements

Machine	Power Consumption	Compressed Air Supply	Air Knife Consumption	Exhaust Dust Extraction
EVOLUTION 4	4.4 kW	40 CFM at 90 PSI	26 CFM	600 - 1000 CFM
EVOLUTION 8	6.5 kW	60 CFM at 90 PSI	31 CFM	600 - 1000 CFM

Figures are based on typical machine use and defect levels. Actual usage may vary.

Temperature and Sound

Machine	Temperature (Max)	Sound Level
EVOLUTION 4	105° F / 40° C	< 85 dBA
EVOLUTION 8	105° F / 40° C	< 85 dBA

Setting the Standards.

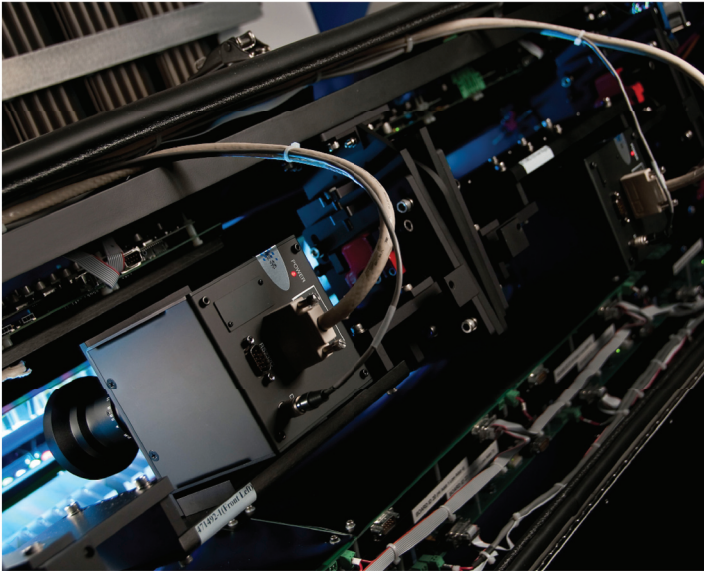

Satake engineering, research and development teams continue to set optical inspection and sorting standards year after year. Many of the common technologies used today, Satake developed and refined over the last 10 to 15 years. Full color RGB, InGaAs, and multiple wavelength viewing are a few of the technologies Satake has pioneered. These have been primary innovations integrated into the Satake EVOLUTION® platform. Below are the current optical sorting technologies Satake offers.



Full Color RGB

Satake RGB technology provides the highest level of true color imaging in the industry using the latest solid state technology (high power LEDs and full color cameras). A near identical representation of natural color variations similar to what the human eye sees.



Shape Recognition

Shape recognition allows the EVOLUTION to easily detect foreign material or specifically-shaped (over and undersized for example) product of the same color that may not fit a certain sort criteria.

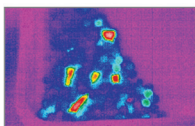

Multi-Wavelength Infrared (MIR)

Innovative camera technology that spans the visible and infrared (IR) spectrum, using both CCD and InGaAs sensors. The MIR model can detect multiple visible wavelengths at the same time as multiple IR wavelengths.

The Satake Advantage.

Building the highest quality optical sorting machine is only part of the equation. Equally important to Satake is offering unmatched, industry-leading after sales customer service and support.

Should an issue or question arise with an EVOLUTION® sorter, Satake has trained personnel with decades of experience ready to answer the phone or respond to email. One of Satake's highest corporate goals is 100 percent customer satisfaction.

Satake machines are built to last. The EVOLUTION is designed with an expected lifespan of over 15 years. Local highly-skilled technicians are quickly dispatched to the facility to complete scheduled service evaluations and install any new or upgraded parts.

That, is the **Satake Advantage.**



Worldwide Customer Service and Support

Global Support and International Standards.

Manufactured in the United States, Satake also offers EVOLUTION sales, spare parts, technical support personnel and demonstration facilities around the world. Satake maintains a team of multilingual and knowledgeable field service engineers and sales staff in strategic locations across the globe.



SATAKE

www.satake-usa.com

North, Central, South America

Satake USA, Inc. (Corporate Office)
Houston, Texas USA
281.276.3600
vision@satake-usa.com

West Coast USA

Satake USA, Inc.
Modesto, California USA
209.551.3203
jsargent@satake-usa.com

Europe, Middle East, Africa

Satake Europe Limited
Stockport, Cheshire, England
44.161.406.3800
sales@satake-europe.com

